



NCS-TT108 Temperature Transmitter User Manual

Content

Chapter 1 Overview	2
Chapter 2 Installation	4
2.1 Mount of Transmitter	4
2.2 Connection	5
Chapter 3 Working Principle and Structure	8
3.1 Principle Introduction	9
3.2 Dimensions	10
3.3 Structure	11
Chapter 4 Configuration	12
4.1 Topology Connection	12
4.2 Function Block	13
4.3 Transducer Block Configuration	13
4.4 Parameter List of Temperature Sensor Transducer Block	17
4.5 Parameter List of Differential Transducer Block	18
4.6 Configuration Setting and Indicating	19
Chapter 5 Maintenance	21
Chapter 6 Technical Specifications	23
6.1 Basic Parameters	23
6.2 RTD Technical Parameter	23
6.3 Thermocouple Parameter	24
6.4 Physical Parameter	24
6.5 Model Reference	25

Chapter 1 Overview

NCS-TT108 Smart Temperature Transmitter, using the fieldbus technology, is a new generation of smart fieldbus temperature transmitter and it is an indispensable field device for process control. NCS-TT108 transmitter integrates abundant function blocks and realizes not only general measurement function but also complicated control strategy.

NCS-TT108 Smart Temperature Transmitter supports eight-channel temperature sensor input. It applied to a variety of thermal resistance and thermocouple sensors and has wide range. Each channel support individually configure the sensor type and two-wire system and three-wire system connections of the thermal resistance. Eight channels are divided into four groups of temperature acquisition modules, with the security isolation between modules. Each temperature acquisition module has two temperature input channels.

NCS-TT108 Smart Temperature Transmitter adopts PVC fire-retardant plastic shell, which can be installed in the control room. When it is required to be installed outdoors, outdoor Aluminum box, with a water-proof body and die-cast aluminum materials, must be selected.

NCS-TT108 uses digital technology. It has simple interface between field and control room, which reduces the expense of installation, operation and maintenance.

NCS-TT108 supports FF and PA protocols. It can be widely used in the petroleum, chemicals, electricity, and metallurgical industries, etc.

Chapter 2 Installation

2.1 Mount of Transmitter

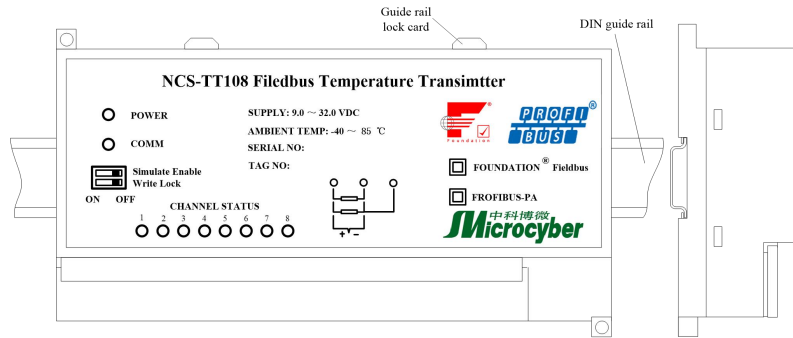

Figure 2.1 Mount of guide rail

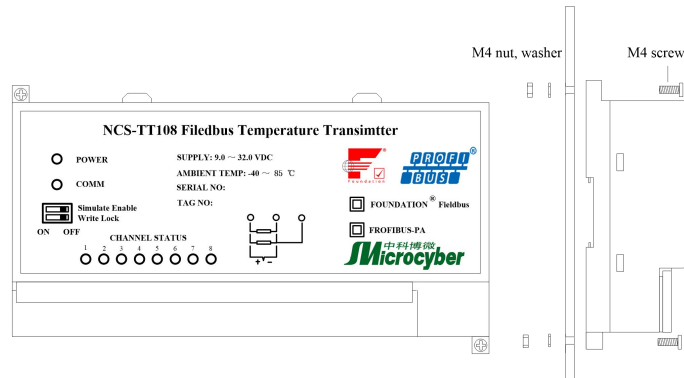

Figure 2.2 Mount of screw

When the temperature transmitter needs mounting in outdoor, it must be mounted in outdoor box, whose case material is die-casting aluminum, and cable seal point is copper chroming.

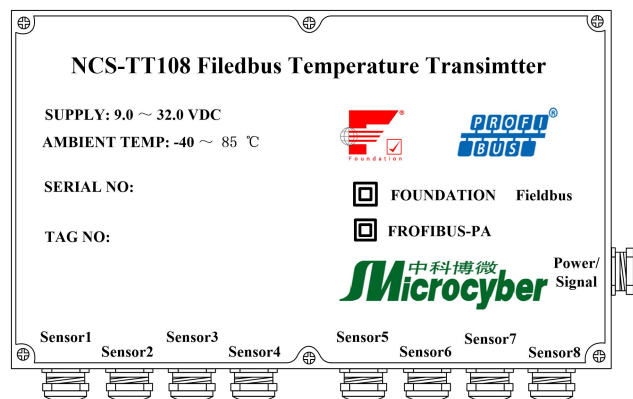

Figure 2.3 Outdoor case

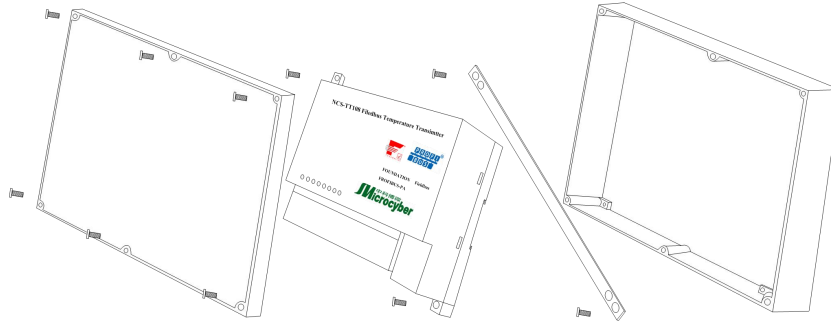

Figure 2.4 Mounted in outdoor box

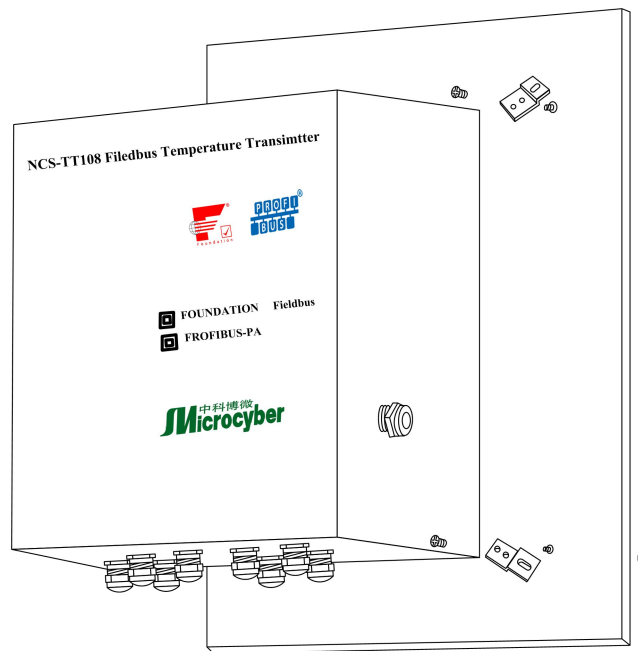

Figure 2.5 Outdoor case surface mounting

2.2 Connection

NCS-TT108 Temperature transmitter's power and bus signal share one couple cable, called bus cable. Customer is advised to use dedicated cable especially for fieldbus, recommended by IEC61158-2. The bus connection terminal of this temperature transmitter is positioned at the

very right of connection terminals. From left to right, they are 'bus+', 'bus-' and 'earth', as showed in the following figure.

Of the left terminals of sensor's signal connection terminal strip, every three terminals in sequence form one channel's connection terminal, and will connect channel one to channel eight sensors, from left to right in sequence. The detailed connection mode is showed as following figure.

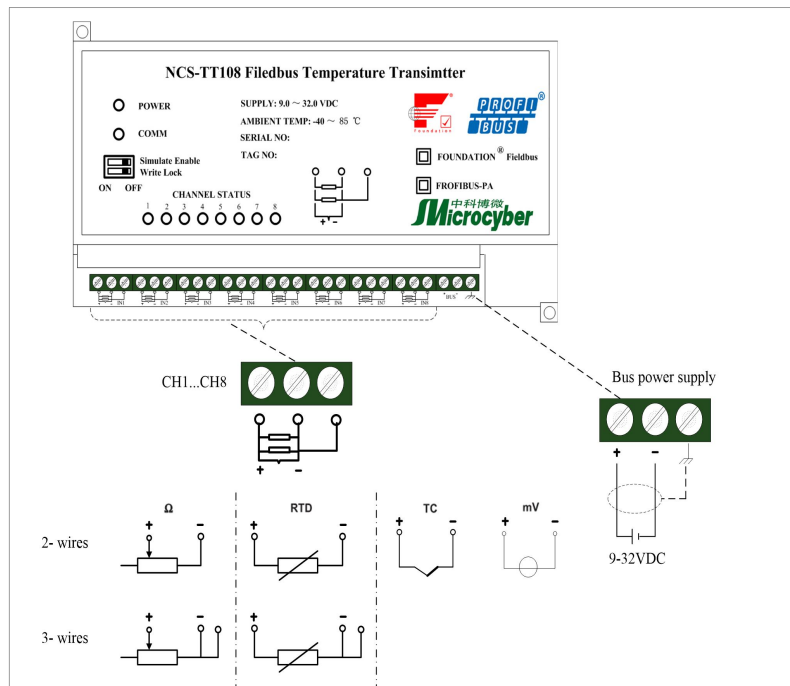

Figure2.6 Temperature transmitter connection

Signal cable and bus cable shall not share wiring tube or open wire trunking with other device and shall be far away from high-power device.

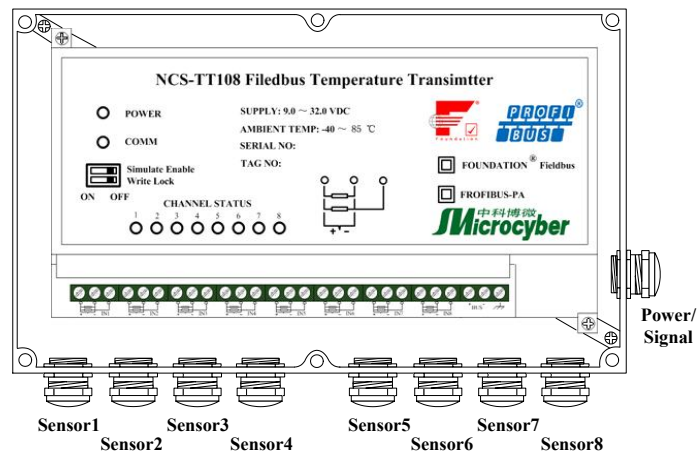

Figure2.7 Cable sealing connector

There are nine cable sealing connectors for outdoor box. The connector on side wall, labeled 'Power/Signal', should connect fieldbus cable, and cable connectors on inferior wall should connect every channel sensor to connect cable, from left to right they are channel one, channel two...channel eight in sequence.

Chapter 3 Working Principle and Structure

NCS-TT108 collects thermo resistance and thermocouple signal, which is converted into fieldbus signal after arithmetic and handling, and achieves temperature measurement functions.

NCS-TT108 mainly consists of two parts. The hardware structure is shown as Figure 3.1.

1. Communication board: It is the core component of smart temperature transmitter. It provides fieldbus communication, control, diagnosis and maintain.
2. Instrument board: It connects 8-channel temperature transmitter, converts the temperature sensor's signal to digital signal and finishes temperature arithmetic. It provides the signal to communication board via isolation communication interface, connects the bus and converts to communication board.

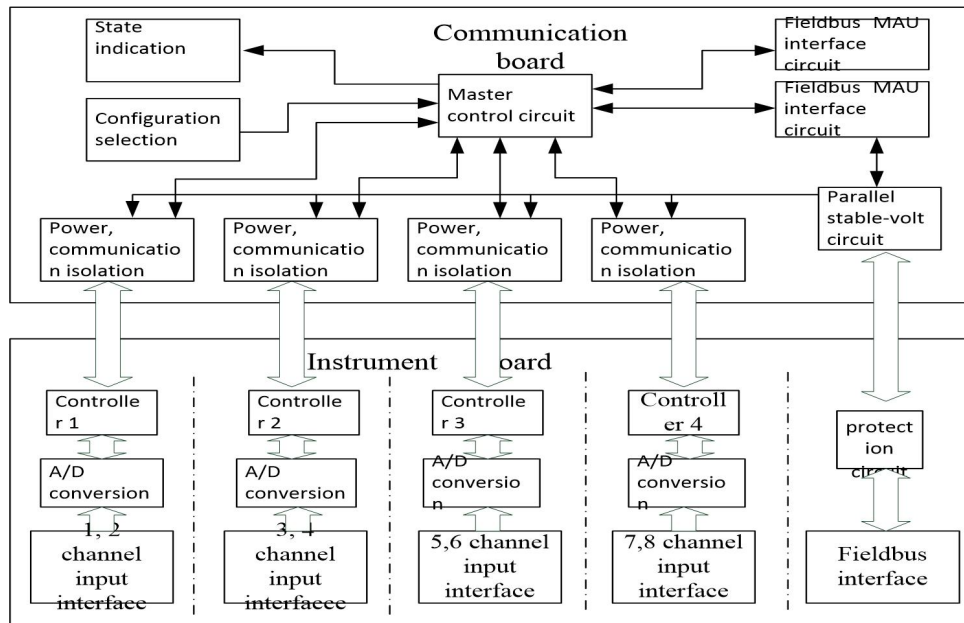

Figure 3.1 Hardware diagram of smart temperature transmitter

3.1 Principle Introduction

Instrument board interface is connected to field bus. Via pressing, over-current protection to communication board, which is in parallel with stable-volt circuit, to produce 3.3V direct current. Via four groups of isolation—DC/DC isolation module, it achieves stabilivolt again, and provides volt to four groups of temperature collecting module. Every group of temperature collecting module includes two-channel temperature converting unit. Each single channel alone can set sensor type and thermo resistance wiring; Via four magnetic isolation component, communication Board's master control circuit serial communicates with four groups of collecting module, and can set and

read temperature value respectively. Four groups of temperature collecting module are isolated respectively. Within collecting modules, two temperature input channels are not isolated.

Communication board indicates the working state of temperature transmitter via ten indicator lights. Two DIP switches set configuration. Master control circuit visits circuit via media, and communicates with field bus.

3.2 Dimensions

Dimensions are shown as the following:

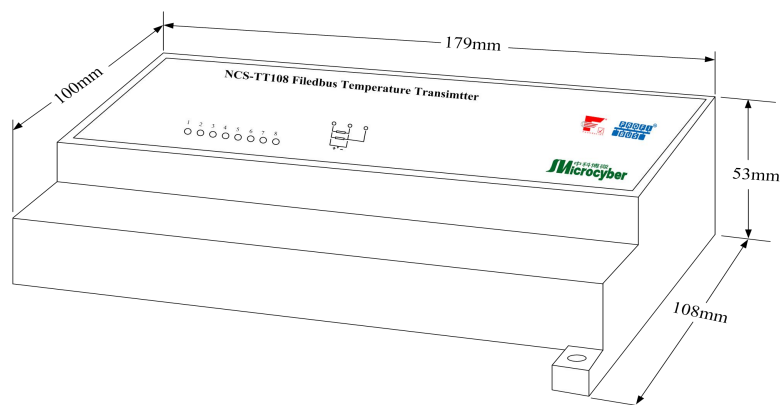
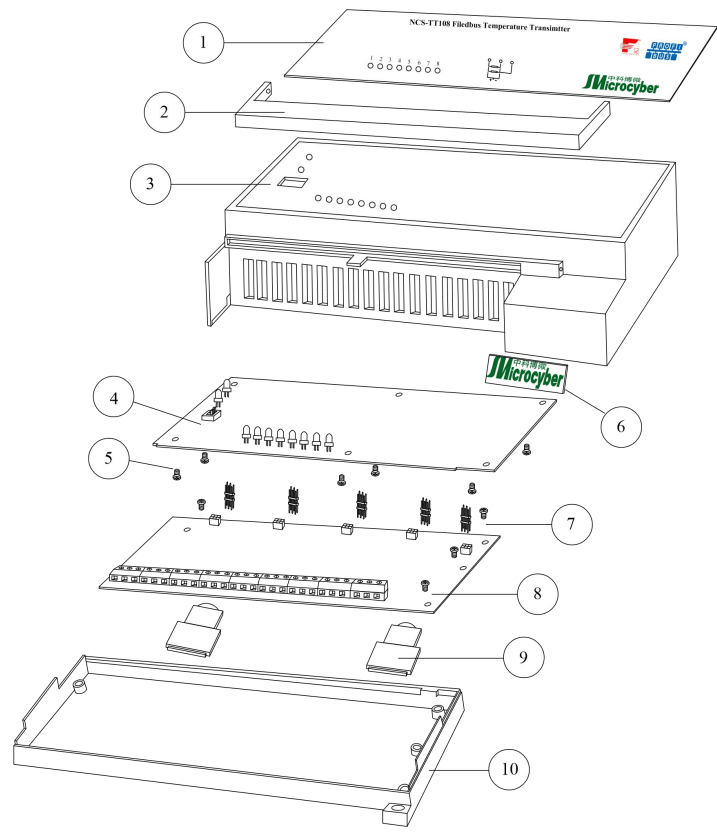

Figure 3.2 Dimensions

3.3 Structure



1	PVC film	2	Block board	3	Roof cover	4	Communication board
5	Tightening screw	6	PVC label	7	Pin	8	Instrument board
9	Rail guide lock	10	Bottom cover				

Figure 3.3 Transmitter structure

Chapter 4 Configuration

4.1 Topology Connection

NCS-TT108 Smart Temperature Transmitter supports many kinds of connection, as shown in Figure 4.1. In Figure 4.2, there's a transmitter bus connection, and the bus ends are connected with terminal matching resistance, which ensures the signal quality. The maximum length of bus is 1900m and it can be prolonged to 10km with repeaters.

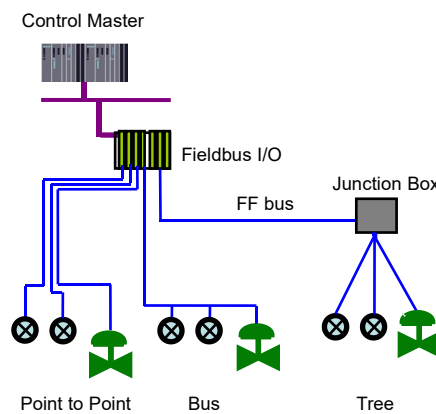

Figure 4.1 FF network topology

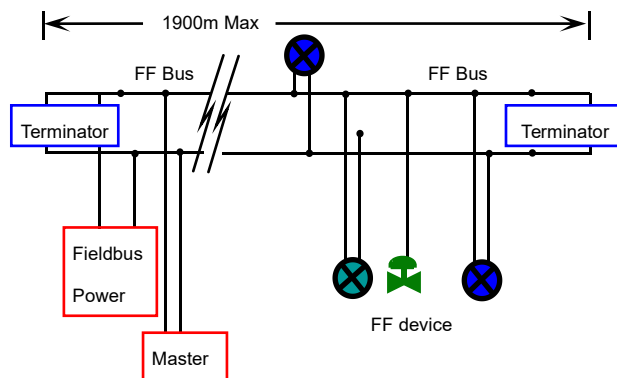

Figure 4.2 FF bus connection

4.2 Function Block

NCS-TT108 Smart Temperature Transmitter realizes FF standard blocks, shown as below. Please refer to related FF Protocol documents for detailed info about function block setting.

Function Block	Description
Resource	Resource block is used to describe device characters in the field, such as device name, manufacture, serial number. There is no input or output parameter in resource block. Generally there is only one resource block for each device.
Sensor Transducer	Temperature sensor transducer block reads physical channel data of temperature sensor, and has data processing based on sensor type. It's used for AI or MAI function block.
Differential Transducer	By parameter setting, differential transducer block may realize difference calculation of any two physical channels.
AI	Analog input function block is used to achieve transducer block input data and transfer it to other function blocks, and has the function of range conversion, square root, cut mantissa, etc.
MAI	Multi-channel analog input function block is used to achieve input data of several transducer blocks, and may transfer it to other function blocks.
ISEL	Input selection function block selects input based on options, such as options of max., min., or medium value, etc., to calculate output.

4.3 Transducer Block Configuration

Smart temperature transmitter supports FF Configuration Software, NCS4000 Configuration Software from Microcyber, NI-FBUS Configurator from NI, Delta V from Rosemount, etc. Now take NI-FBUS Configurator as an example to introduce the configuration method of smart temperature transmitter.

- Configuration Environment

(1) PC, Windows 2000 or Windows XP;

(2) NI-FBUS interface card, H1 bus power, H1 terminator;

(3) NI-FBUS Configurator.

- Sensor Type Configuration

Sensor type of corresponding physical channel can be set by modifying each sensor transducer block SENSOR_TYPE parameter, such as PT100, CU50, etc.

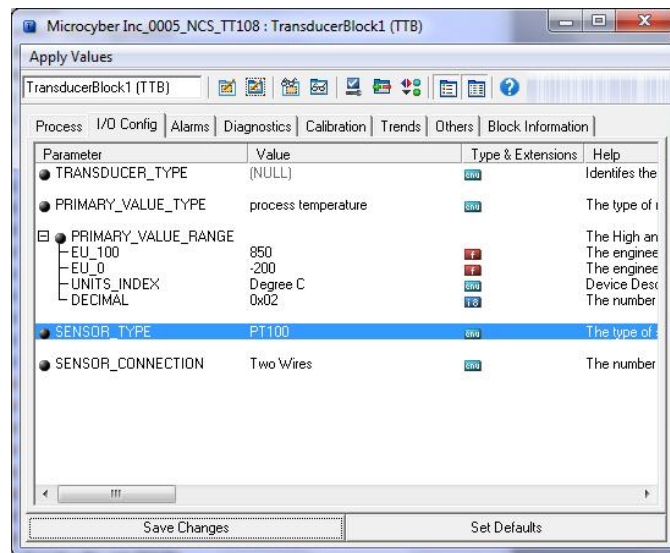

Figure 4.3 Sensor type configuration

- 2-wire Zero Point Calibration Configuration

For 2-wire measurement, 2-wire zero point calibration can be realized by modifying sensor transducer block's TWO_WIRES_COMPENSATION parameter. Firstly, give zero point value to channel to make a short circuit. Then set the TWO_WIRES_COMPENSATION parameter as "Start" to write in. If it is successful, read the parameter. If the parameter value is "Finished", it means that 2-wire zero point calibration is successful.

- Enable Cold End Compensation

If the sensor is thermocouple, transducer block BODY_TEMP parameters show cold end temperature value. The sensor firstly enables cold end compensation by default. The user also may set cold end compensation via parameter BODY_TEMP_COMPENSATION. When it is set as “Enable”, it enables cold end compensation. At this time, PRIMARY_VALUE value is the temperature value after cold end compensation. When it is set as “Disable”, the cold end compensation is forbidden. At this time, PRIMARY_VALUE value is the temperature value without cold end compensation.

- 2-point Linearization Calibration

Smart temperature transmitter has strict calibration in factory. Generally, it is not necessary for user to calibrate. The user can use CAL_POINT_HI, CAL_POINT_LO and CAL_UNIT to realize 2-point linearization calibration. The operation steps shown as following:

- (1) Make sure and set SESOR_TYPE, and set CAL_UNIT according to sensor type. Now it supports Celsius, Ohms and MV.
- (2) Set transducer block MODE parameter as “OOS”, and then set the SENSOR_CAL_METHOD as “User Trim Standard Calibration”.
- (3) Give standard data to channel to calibrate via standard source, when the input is stable, write calibration data to CAL_POINT_HI or

CAL_POINT_LO according to upper limit calibration or lower limit calibration. It is successful if there is no write error.

Notes: The calibration will be failed if there is a great deviation between write-in calibration data and practical input channel data.

- Differential Transducer Block Configuration

Smart temperature transmitter has 4 differential transducer blocks, by which, realize difference calculation between any two physical channel data. Select sensor transducer block via parameter INPUT_A and INPUT_B. Configure difference calculation type via parameter DIFFERENTIAL_TYPE. If DIFFERENTIAL_TYPE = "Not Used", difference calculation isn't done by the differential transducer block. If DIFFERENTIAL_TYPE = "Input A - Input B", output of the difference transfer block is INPUT_A - INPUT_B. If DIFFERENTIAL_TYPE = "Absolute", output of the difference transfer block is absolute value of difference between INPUT_A and INPUT_B. What calls for attention is that the two sensor transducer blocks to do difference calculations must use the same unit; otherwise, output of differential transducer block will display "Bad Configuration Error".

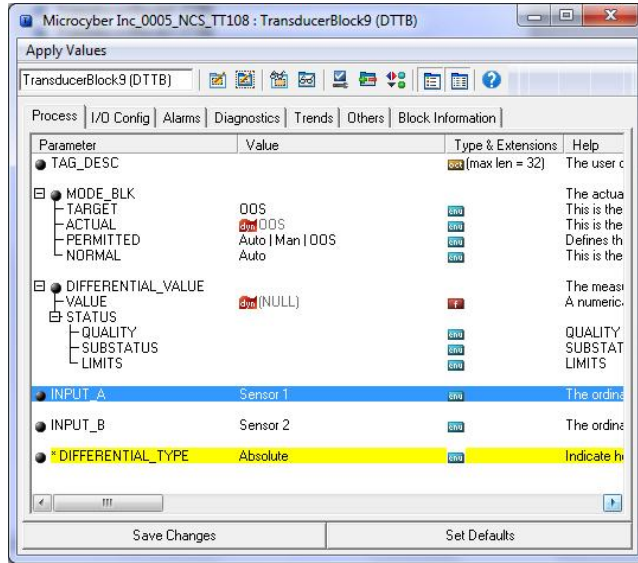

4.4 Parameter List of Temperature Sensor Transducer Block

Index	Parameter Name	Parameter Description
1	ST_REV	Static Version
2	TAG_DESC	Tag No.
3	STRATEGY	Strategy
4	ALERT_KEY	Alert ID number
5	MODE_BLK	Mode
6	BLOCK_ERR	Error
7	UPDATA_EVT	Update affair of static data
8	BLOCK_ALM	Function block alarm
9	TRANSDUCER_TYPE	Transducer block type
10	XD_ERROR	Transducer block error description
11	PRIMARY_VALUE_TYPE	Primary value types are "Process Temperature" and "Non Process Temperature"
12	PRIMARY_VALUE	Primary value is channel measurement data, which is transferred to function block AI and MAI via CHANNEL of function block.
13	PRIMARY_VALUE_RANGE	Range and unit of primary value. The unit shall be the same with XD_SCALE of function block AI. Otherwise, function block AI will display "Configuration Error".
14	SENSOR_TYPE	Sensor types are "0-500 Ohms", "0-4000 Ohms", "CU50", "CU100", "PT100", "PT1000", "-/+100mV", "T/C Type B", "T/C Type E", "T/C Type J", "T/C Type K", "T/C Type N", "T/C Type R", "T/C Type S" and "T/C Type T".
	SENSOR_RANGE	Sensor range, there will be different ranges based different sensor types.
15	SENSOR_SN	Sensor Serial No.

16	SENSOR_VERSION	Version number of sensor measurement board
17	SENSOR_CONNECTION	Sensor wire system, supports two-wire system and three-wire system.
18	CAL_POINT_HI	Summit calibration value. Its unit is assigned by CAL_UNIT.
19	CAL_POINT_LO	Lowest point calibration value. Its unit is assigned by CAL_UNIT.
20	CAL_MIN_SPAN	Min span permitted by calibration. The min span guarantees smooth calibration progress, and make the distance between the highest and lowest points of the calibration not too close. Its unit is assigned by CAL_UNIT.
21	CAL_UNIT	Calibration unit, now only supports Celsius, Ohms and MV.
22	SENSOR_CAL_METHOD	Calibration method may select "Factory Trim Standard Calibration" and "User Trim Standard Calibration".
23	SENSOR_CAL_LOC	Calibration location record.
24	SENSOR_CAL_DATE	Calibration data record.
25	SENSOR_CAL_WHO	Calibration personnel record.
26	BODY_TEMP	Instrument temperature. It is cold end temperature.
27	BODY_TEMP_UNIT	Unit of BODY_TEMP
28	BODY_TEMP_COMPENSATION	Enable cold end temperature compensation.
29	TWO_WIRES_COMPENSATION_CMD	2-wire system calibration command
30	SENSOR_STATUS	Sensor status includes "Enabled", "Disabled", "Open circuit", "Cfg Error" and "Comm Error".
31	SENSOR_AD_DATA	Sensor data of AD gather
32	BODY_AD_DATA	Instrument temperature data of AD gather

4.5 Parameter List of Differential Transducer Block

Index	Parameter Name	Parameter Description
1	ST_REV	Static version
2	TAG_DESC	Tag No.
3	STRATEGY	Strategy
4	ALERT_KEY	Alert ID number
5	MODE_BLK	Mode
6	BLOCK_ERR	Error
7	UPDATA_EVT	Update affair of static data
8	BLOCK_ALM	Function block alarm
9	TRANSDUCER_TYPE	Transducer block type
10	XD_ERROR	Transducer block error description
11	DIFFERENTIAL_VALUE	Differential value, is difference data after calculation.
12	DIFFERENTIAL_VALUE	Differential value range, calculate based on selected sensor channel range.

	_RANGE	
13	INPUT_A	The first sensor to select difference calculation, from "Sensor 1" to "Sensor 8".
14	INPUT_B	The second sensor to select difference calculation, from "Sensor 1" to "Sensor 8".
15	DIFFERENTIAL_TYPE	Difference calculation type, 0:"Not Used", 1:"Input A - Input B", 2:"Absolute".

4.6 Configuration Setting and Indicating

NCS-TT108 Smart Temperature Transmitter has two DIP switches, as shown in Figure 4.4:

Simulate Enable: Set "ON" to realize simulate function.

Write Lock: Set "ON", any write-in operation to temperature transmitter will be refused. This is to prevent that instrument's data is changed at random.

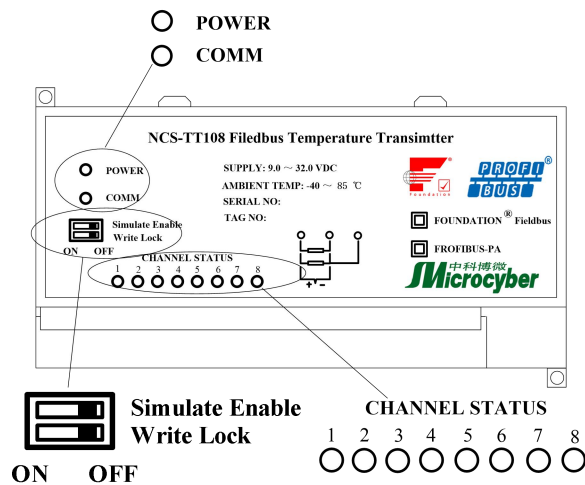

Figure 4.4 DIP switch of NCS-TT108 Smart Temperature Transmitter

NCS-TT108 smart temperature transmitter has ten indicating lights, to show bus power status, communication status and the working status of eight temperature input channels, as shown in the upper figure.

Input Channel Status Indicating:

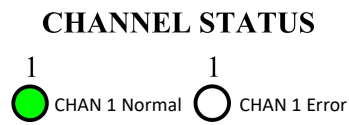

Figure 4.5 Status Instruction of Channel 1

0.5s is communication error;

1s is configuration error;

No.1 indicating light shows the status of the first temperature transfer channel, and so on; Indicating methods of the eight channels are the same.

Indicating of Power and Communication:

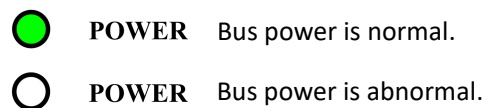

Figure 4.6 Indicating of Power Status

“COMM” indicating light shows bus communication status. The indicating light flashes, when communication data package is sent and received in the connected field bus. The indicating light status is stationary, when the connected field bus is silent.

Chapter 5 Maintenance

Phenomenon	Solution
No Communication	<p>Temperature Transmitter Connection Check the bus cable connection Check bus power polarity Check bus cable shield, whether it is single point earthing or not.</p>
	<p>Bus Power Bus power should in the range 9~32V for the temperature module, and bus noise and ripple should fulfill: (1)peak-to-peak value noise 16mV, 7~39kHz; (2)peak-to-peak value noise 2V, 47~63HZ, non-intrinsically safety (3)peak-to-peak value noise 0.2V, 47~63HZ, intrinsically safety (4)peak-to-peak value noise 1.6V, 3.9M~125Mz.</p>
	<p>Network Connection Check network topology structure Check terminal matcher and wiring Check the length of main trunk and branch</p>
	<p>Address Conflict When coming to market, the temperature module has a random address, avoiding address conflict. But on a network segment it still possibly appears address conflicts. When conflict occurs, sometimes conflicting device will be temporary address online, you should just reset the device address. Sometimes device will not be temporary address online, you should cut off the electricity of conflicting device, and then power them one by one, modify the address of new powered device as non-conflicting.</p>
	<p>Temperature Module Failure Replace the temperature module with others for testing.</p>
Reading Error	<p>Temperature Module Connection Failure Check sensor short circuit, open circuit, and earthing. Check sensor</p>
	<p>Noise Disturb Adjust damping Check the house earthing Check the terminal Check the cable is away from the strong electromagnetic interference</p>

	Software Configuration Check sensor type configuration Check function block parameter configuration
	Temperature Module Failure Replace the temperature module with others for testing

Chapter 6 Technical Specifications

6.1 Basic Parameters

Input Signal	Resistance: PT100, CU50, CU100, 0~500Ω, 0~4000Ω Thermocouple: B, E, J, N, K, R, S, T Voltage signal: -100mV~100mV
Channel	8-channel
RTD Wiring	2-wire, 3-wire,
Bus Power	9~32 VDC Current consumption (static): ≤20mA
Bus Signal	Communication ratio 31.25Kbit/s, current mode
Isolation	Between input channel and bus: 500Vrms (707 VDC) Between temperature converter module: 500Vrms (707 VDC) The two temperature input channels in the module are not isolated.
Working Temperature	-40℃~85℃
Humidity Range	0%~100%RH
Start Time	≤5s
Refresh Time	0.2s
Protection	IP20; Outside box IP67
Vibration	Arbitrary axial 0~200Hz, error is±0.05%/g of largest range
EMC	Bus terminal: GB/T 18268-2000 Table A1 Sensor terminal: GB/T 18268-2000 Table 1

6.2 RTD Technical Parameter

● RTD Accuracy Parameter at Normal Temperature (25℃)

Signal Type	Suggested Range (℃)	Accuracy
Resistance Signal	0~500Ω,0~4000Ω	±0.05%
PT100	-200 ~ 850℃	±0.2℃
PT1000	-200 ~ 850℃	±0.1℃
CU50	-50 ~ 150℃	±0.3℃
CU100	-50~ 150℃	±0.2℃

● RTD Other Parameter

Wiring	2, 3
Data Refresh Ratio	≥ 1Hz/each channel
Common Mode Rejection	≥80Db (50Hz)
Series Mode Rejection	≥60dB(50Hz)
Temperature Drift	±0.001/°C

6.3 Thermocouple Parameter

● Thermocouple Accuracy Parameter at Normal Temperature (25°C)

Signal Type	Suggested Range (°C)	Accuracy
mV	-100 mV ~100mV	0.05%
B	500°C~1810°C	±1.0°C
E	-200°C~1000°C	±0.6°C
J	-190°C~1300°C	±0.8°C
K	-200°C~1372°C	±0.8°C
N	-190°C~1300°C	±1.0°C
R	0°C~1768°C	±1.0°C
S	0°C~1768°C	±1.0°C
T	-200°C~400°C	±0.6°C

● Thermocouple Other Parameter

Compensation Accuracy	< ±1°C
Data Refresh Ratio	≥ 1Hz
Sensor Type	B,E,J,N,K,R,S,T -100mV~100mV Voltage
Common Mode Rejection	≥60Db (50Hz)
Series Mode Rejection	≥60dB(50Hz)
Temperature Drift	±0.001/°C

6.4 Physical Parameter

Material	Flame retardant plastic;Die-casting aluminum (outside box)
Protection	IP20; Outside box IP67
Weight	0.42kg 1.98kg (With outside box)

6.5 Model Reference

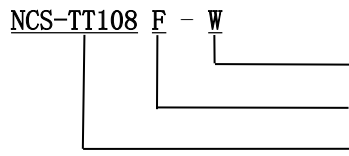

Selective Outside Box
FF-H1 Protocol
Product Model